

# PARTS CATALOG

Fig.1 POWER UNIT



KEY	DESCRIPTION	QTY	KEY	DESCRIPTION	QTY
1	CYLINDER	1	23	OIL SEAL(R)	1
2	INLET PIPE	1	24	STUD	2
3	PIPE GASKET	1	25	ELBOW	1
4	SCREW	2	26	STOPPER(R)	1
5	INLET PIPE GUIDE	1	27	STOPPER(L)	1
6	CARBURETOR BRACKET	1	28	CRANKCASE GASKET	1
7	SCREW	2	29	SCREW	5
8	ASBESTOS MAT	1	30	VACUUM PIPE	1
9	SPACER	1	31	CLIP	2
10	CYLINDER GASKET	1	32	UNDER MAT	1
11	SCREW	4	33	PISTON	1
12	MUFFLER BOLT	2	34	PISTON RING	2
13	MUFFLER NUT	2	35	PISTON PIN	1
14	MUFFLER	1	36	CIRCLIP	2
15	SCREW	2	37	NEEDLE BEARING	1
16	GASKET	1	38	WASHER	2
17	SPACER	1	39	CRANKSHAFT COMP	1
19	SPRING PIN	2	40	KEY	1
20	BALL BEARING	2	41	LEFT CRANKCASE	1
21	SNAP RING	1	42	RIGHT CRANKCASE	1
22	OIL SEAL(L)	1	44	GUIDE(L,H)	1

Fig.2 IGNITION, STARTING

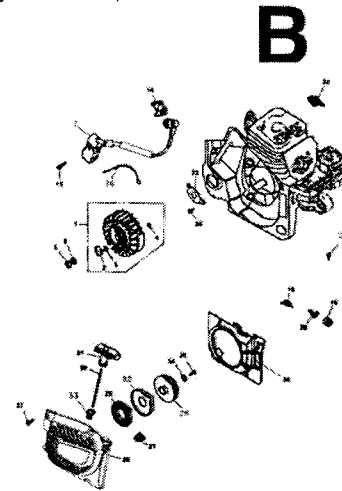

KEY	DESCRIPTION	QTY	KEY	DESCRIPTION	QTY
1	FLYWHEEL ASSY	1	23	PLATE	1
2	PAWL	2	24	SCREW	2
3	SPRING	2	26	STARTER COVER	1
4	SNAP RING	2	27	GUIDE(L,H)	1
5	NUT	1	28	STARTER REEL	1
6	WASHER	1	29	RECOIL SPRING COMP	1
7	IGNITION ASSY	1	30	NYLON ROPE	1
14	DUST SHIELD	1	31	STARTER KNOB	1
15	SCREW	2	32	SPRING PLATE	1
16	CORD	1	33	ROPE GUIDE	1
18	SWITCH(ON/OFF)	1	34	REEL WASHER	1
19	SWITCH COVER	1	35	SCREW	1
20	GROUND PLATE	1	36	FAN COVER	1
21	SCREW	1	37	SCREW	4
22	SPARK PLUG	1			

Fig.3 HANDLE

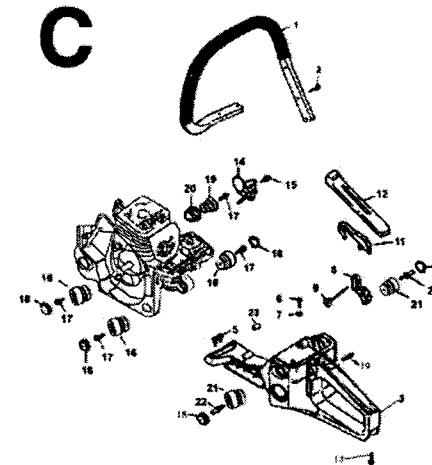

KEY	DESCRIPTION	QTY
1	FRONT HANDLE COMP	1
2	SCREW	4
3	REAR HANDLE ASSY	1
5	DAMPER	1
6	SCREW	1
7	GASKET	1
8	THROTTLE LEVER	1
9	THROTTLE SPRING	1
10	SPRING PIN	1
11	THROTTLE INTERLOCK ARM	1
12	REAR HANDLE COVER	1
13	SCREW	1
14	CHAIN CATCHER	1
15	SCREW	1
16	DAMPER	3
17	SCREW	4
18	CAP	5
19	SPRING	1
20	SPRING SET	1
21	DAMPER	2
22	SCREW	2
23	LESSEN VIBRATION PLUG	1

**Fig.4 FUELING SYSTEMS**

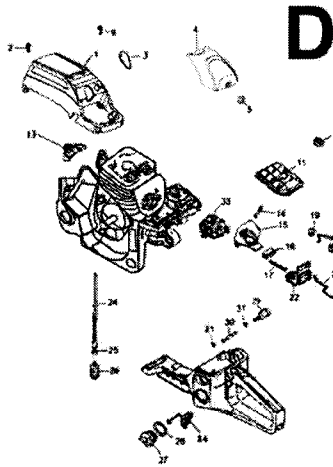

KEY	DESCRIPTION	QTY	KEY	DESCRIPTION	QTY
1	CYLINDER TOP COVER	1	19	CHOKE ROD GUIDE	1
2	SCREW	2	20	CHOKE ROD DAMPER	1
3	HOT WIND COVER	1	21	THROTTLE ROD	1
4	AIR FILTER COVER	1	22	DUST SHIELD	1
5	AIR FILTER COVER KNOB	1	24	FUEL PIPE	1
6	AIR FILTER KNOB	1	25	FUEL PIPE COLLAR	1
9	SCREW	2	26	FUEL FILTER ASSY	1
11	AIR FILTER COMP	1	27	FUEL TANK CAP ASSY	1
13	GUIDE (T)	1	28	FUEL TANK CAP WASHER	1
14	STUO	1	29	BREATHER ASSY	1
15	MANIFOLD COMP	1	30	BREATHER PIPE	1
16	DAMPER	1	31	CIRCLIP	2
17	SCREW	2	33	CARBURETOR	1
18	CHOKE KNOB	1	34	CAP LINK	1

**Fig.5 OIL SYSTEM, CLUTCH**

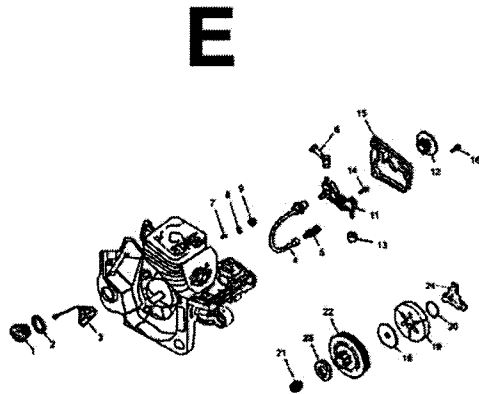

KEY	DESCRIPTION	QTY
1	OIL TANK COVER ASSY	1
2	OIL TANK CAP GASKET	1
3	CAP LINK	1
4	OIL PUMP PIPE(I)	1
5	OIL FILTER ASSY	1
6	OIL PUMP PIPE(O)	1
7	BREATHER VALVE	1
8	SPONGE	1
9	RING	1
11	OIL PUMP ASSY	1
12	OIL PUMP WORM	1
13	SEALED SPONGE	1
14	SCREW	2
15	OIL PUMP COVER	1
16	SCREW	3
18	CLUTCH WASHER	1
19	CLUTCH WEDGE	3
20	CLUTCH SPRING	1
21	NEEDLE BEARING	1
22	CLUTCH DRUM	1
23	SPROCKET	1
24	WEDGE BRACKET	1

**Fig.6 BREAKING SYSTEMS**

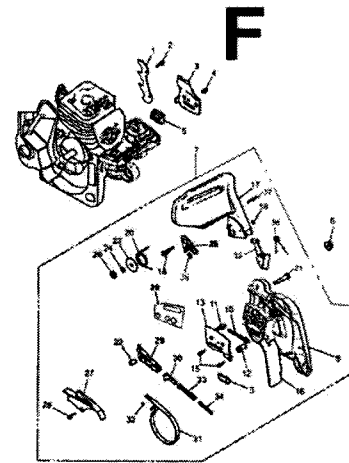

KEY	DESCRIPTION	QTY	KEY	DESCRIPTION	QTY
1	SPIKED BUMPER	1	21	GUIDE PIN	1
2	SCREW	2	22	GUIDE PIN SLEEVE	1
3	OIL GUIDE PLATE	1	23	PLATE WASHER	1
4	SCREW	1	24	SNAP RING	1
5	CHAIN GUIDE	2	25	STOPPER PLATE	1
6	NUT	2	26	RUBBER WASHER	1
7	CLUTCH COVER ASSY	1	27	BRAKE SPRING COVER	1
8	CLUTCH COVER	1	28	SCREW	3
10	TENSIONED BOLT	1	29	BRAKE LEVER COMP	1
11	TENSIONER PIN	1	30	BRAKE ARM	1
12	TENSIONER SCREW	1	31	BRAKE BAND	1
13	TENSION PLATE	1	32	ROLLER	1
15	SCREW	2	33	BRAKE SPRING(MAIN)	1
16	SAWDUST PROTECTOR	1	34	BRAKE SPRING(SUB)	1
17	FRONT HAND GUARD	1	35	HOOK	1
18	STOP PIN	1	36	TORSIONAL SPRING	1
19	SNAP RING	1	37	PIN	1
20	BRAKE SPRING	1	38	SNAP RING	1
			39	PAPER GASKET	1

**Fig.7 GUIDE BAR, SAW CHAIN, TOOLS**

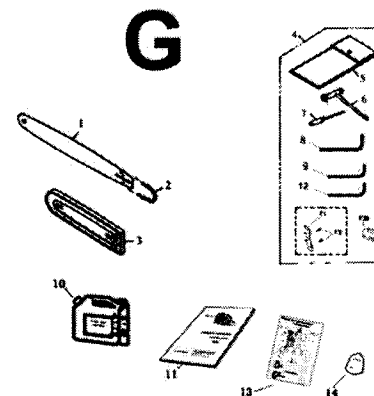

KEY	DESCRIPTION	QTY
1	GUIDE BAR	1
2	SAW CHAIN	1
3	GUIDE BAR COVER	1
4	ATTACHED TOOLS	1
5	TOOL BAG	1
6	SPARK PLUG WRENCH	1
7	SCREW DRIVER	1
8	T25 WRENCH	1
9	S4 HEXAGON RING SPANNER	1
10	FUEL MIXTURE KETTLE	1
11	OWNER'S MANUAL	1
12	S3 HEXAGON RING SPANNER	1
13	PACKING LIST	1
14	ACCEPTANCE CERTIFICATE	1